

Larson Engineering, Inc.
3524 Labore Road
White Bear Lake, MN 55110-5126
651.481.9120 Fax: 651.481.9201
www.larsonengr.com



**6670 Vernon Avenue
Stair Replacement and Repair
Edina, MN**

**Structural Drawings
Grade Beam
Helical Pile Foundation**

Prepared for
Atlas Restoration and Construction, LLC
Eden Prairie, MN

I hereby certify that this plan, specification, or report was prepared by me or under my direct supervision and that I am a duly Licensed Professional Engineer under the laws of the State of Minnesota.

Print Name: Sean R. Noren

Signature: 

Date: 06/25/2019 License #: 44634

Larson Engineering, Inc.
White Bear Lake, Minnesota
Project Number 11190816.000



GENERAL STRUCTURAL NOTES

1. BUILDING CODES USED FOR DESIGN:
 - a. MINNESOTA BUILDING CODE, 2015 EDITION. (IBC 2012)

2. HELICAL PIERS
 - a. CONTRACTOR SHALL SUBMIT SPECIFICATION DATA, SHOP DRAWINGS, CERTIFIED TEST REPORTS, INSTALLATION PROCEDURES, AND CALCULATIONS CERTIFIED BY A LICENSED PROFESSIONAL ENGINEER REGISTERED IN THE PROJECT STATE FOR THE LOADS LISTED ON PLAN WITH A MINIMUM FACTOR OF SAFETY OF 2.0 APPLIED.
 - b. PIERS SHALL BE INSTALLED BY AN AUTHORIZED INSTALLER PER MANUFACTURER'S RECOMMENDATIONS.
 - c. HELICAL PIERS SHALL BE CERTIFIED BY ICC.
 - d. ALL PIERS MUST BE CORROSION PROTECTED BY HOT-DIP GALVANIZATION.
 - e. A TEST HELICAL PIER INSTALLATION SHALL BE DONE TO DETERMINE THE OPTIMUM LEAD HELIX CONFIGURATION AND FINAL BEARING DEPTHS. THE TESTS SHALL BE IN CONFORMANCE WITH ASTM D-1143 STANDARD TEST FOR PIER UNDER STATIC AXIAL COMPRESSIVE LOAD AND/OR ASTM D3689 STANDARD TEST METHOD FOR PIER UNDER STATIC AXIAL TENSION LOAD. TEST EACH PILE TYPE NEAR THE LOCATION WHERE THEY WILL BE INSTALLED. TEST PILES MAY NOT BE USED FOR FINAL CONSTRUCTION.
 - f. THE SHAFT OF THE PIERS SHALL BE SLEEVED AND GROUTED THROUGH THE SOFT ZONE AS SPECIFIED BY THE GEOTECHNICAL ENGINEER TO A MINIMUM DEPTH OF 20 FEET.
 - g. THE APPROPRIATE HELICAL PIER SELECTION WILL CONSIDER THE DESIGN LOAD PLUS A SAFETY FACTOR, SOIL PARAMETERS AND THE INSTALLATION TORQUE VERSUS CAPACITY EQUATION PER MANUFACTURER'S RECOMMENDATIONS.
 - h. HELICAL PIERS SHALL BE PLACED AS INDICATED ON PLAN. CONTRACTOR SHALL NOT DEVIATE FROM PLAN UNLESS APPROVED BY THE ENGINEER. PIERS SHALL BE INSTALLED WITH HORIZONTAL AS FOLLOWS: CENTERLINE OF PIER SHAFT SHALL BE INSTALLED TO WITHIN 2" MAXIMUM OFFSET FROM PLAN LOCATION ALONG BEAM/WALL CENTERLINE AND WITHIN 1" MAXIMUM OFFSET FROM PLAN LOCATION PERPENDICULAR TO BEAM/WALL CENTERLINE.
 - i. DUE TO THE SLENDER NATURE OF HELICAL PIERS Laterally, SPECIAL PRECAUTIONS MUST BE TAKEN:
 1. GRADE BEAMS AND WALLS MUST BE ADEQUATELY BRACED BY FLOOR SYSTEM AND FLOOR SLAB PRIOR TO BACKFILLING.
 2. PIERS MUST BE INSTALLED AS CLOSE TO CENTERLINE OF BEAMS AS POSSIBLE.
 3. CONTRACTOR SHALL AVOID INDUCING ANY LATERAL LOADS INTO THE PIER SYSTEM, IE COMPACTION LOADS, ECCENTRIC LOADS, ETC.

3. DESIGN LOADS:

a. FLOOR LIVE LOADS:	UNIFORM LOAD	CONC LOAD*
STAIRS AND EXIT WAYS:	=100 PSF	300 LB

4. DESIGN STRESSES:

a. CONCRETE:	TYPE MIX	LOCATION
STRENGTH AT 28 DAYS (PSI)	STD WT AIR-ENTRAINED	GRADE BEAMS
4,000		F _y = 60,000 PSI ASTM A615
b. REINFORCEMENT		(DEFORMED BARS)

5. CONCRETE COVERAGE FOR REINFORCEMENT:

a. GRADE BEAMS	2" SIDES, 3" BOTTOM
----------------	---------------------



6. REINFORCING STEEL:

- a. THE REINFORCING STEEL CONTRACTOR SHALL FABRICATE ALL REINFORCEMENT AND FURNISH ALL ACCESSORIES, CHAIRS, SPACER BARS AND SUPPORTS NECESSARY TO SECURE THE REINFORCEMENT UNLESS SHOWN OTHERWISE ON THE PLANS AND/OR DETAILS.
- b. CONCRETE REINFORCEMENT SHALL BE PLACED ACCORDING TO THE CRSI "RECOMMENDED PRACTICE FOR PLACING REINFORCING BARS".
- c. COMPRESSION AND TENSION LAP SPLICES FOR CAST-IN-PLACE CONCRETE SHALL BE AS INDICATED IN THE "LAP SPLICE LENGTH SCHEDULE FOR CLASS B LAP SPLICES", UNLESS NOTED OTHERWISE.
- d. TOP BARS SHALL BE HOOKED AT END SPANS.
- e. REINFORCING BARS MAY NOT BE WELDED WITHOUT APPROVAL OF THE STRUCTURAL ENGINEER.

7. CONCRETE:

- a. CONCRETE WORK SHALL CONFORM TO ALL REQUIREMENTS OF ACI 301.
- b. EACH CONCRETE MIX SHALL BE DESIGNED BY A REGISTERED ENGINEER. A STAMPED COPY OF EACH MIX DESIGN SHALL BE SUBMITTED TO THE ENGINEER OF RECORD PRIOR TO CONSTRUCTION.
- c. COMPLY WITH ACI 304 FOR MEASURING, MIXING, TRANSPORTING, AND PLACING CONCRETE.
- d. COMPLY WITH ACI 305 FOR HOT WEATHER CONCRETING.
- e. COMPLY WITH ACI 306 FOR COLD WEATHER CONCRETING.
- f. UNLESS SPECIFIED OTHERWISE, CONCRETE MUST REACH THE FOLLOWING PERCENTAGES OF ITS 28 DAY COMPRESSIVE STRENGTH (F'_c) BEFORE FORMS MAY BE REMOVED:
BEAM SIDES 40 PERCENT

8. BACKFILLING:

- a. ALL GRADE BEAMS SHALL BE ADEQUATELY BRACED TO PREVENT LATERAL MOVEMENT DURING BACKFILLING AND COMPACTION.

9. CONSTRUCTION PROCEDURE:

- a. THE STRUCTURE SHALL BE ADEQUATELY BRACED AND SHORED DURING ERECTION AGAINST WIND AND ERECTION LOADS. STRUCTURAL MEMBERS ARE DESIGNED FOR "INPLACE" LOADS.
- b. COMPLY WITH ALL APPLICABLE CITY, COUNTY, STATE AND FEDERAL LAWS, INCLUDING THE OCCUPATIONAL SAFETY AND HEALTH ACT (OSHA) AND REGULATIONS ADOPTED PURSUANT THERETO.
- c. THE CONTRACT STRUCTURAL DRAWINGS AND SPECIFICATIONS REPRESENT THE FINISHED STRUCTURE. UNLESS OTHERWISE NOTED, THEY DO NOT INDICATE THE MEANS OR METHOD OF CONSTRUCTION. PROVIDE ALL MEASURES NECESSARY TO PROTECT THE STRUCTURE, WORKMEN OR OTHER PERSONS DURING CONSTRUCTION. SUCH MEASURES SHALL INCLUDE, BUT ARE NOT LIMITED TO BRACING, SHORING FOR CONSTRUCTION EQUIPMENT, SHORING FOR THE BUILDING, SHORING FOR EARTH BANKS, FORMS, SCAFFOLDING, PLANKING, SAFETY NETS, SUPPORT AND BRACING FOR CRANES AND GIN POLES, ETC.
- d. ENGAGE PROPERLY QUALIFIED PERSONS TO DETERMINE WHERE AND HOW TEMPORARY PRECAUTIONARY MEASURES SHALL BE USED AND INSPECT SAME IN THE FIELD. OBSERVATION VISITS TO THE SITE BY ENGINEER'S FIELD REPRESENTATIVE SHALL NOT INCLUDE INSPECTION OF THE ABOVE ITEMS.
- e. SUPERVISE AND DIRECT THE WORK SO AS TO MAINTAIN SOLE RESPONSIBILITY FOR ALL CONSTRUCTION MEANS, METHODS, TECHNIQUES, SEQUENCES AND PROCEDURES. AS A PART OF THIS RESPONSIBILITY, RETAIN THE SERVICES OF A LICENSED STRUCTURAL ENGINEER TO DESIGN AND SUPERVISE ANY SCAFFOLDING FOR WORKMEN, AND ALL SHORING OF FORMS AND ELEMENTS OF THE CONSTRUCTION.

10. COORDINATION WITH ARCHITECTURAL DRAWINGS:

- a. THE CONTRACTOR SHALL VERIFY ALL DIMENSIONS AND ELEVATIONS WITH THE ARCHITECTURAL DRAWINGS. WHERE DISCREPANCIES OCCUR, IT IS THE CONTRACTOR'S RESPONSIBILITY TO NOTIFY THE ARCHITECT PRIOR TO CONSTRUCTION.



11. NEW WORK IN CONJUNCTION WITH EXISTING CONSTRUCTION:

- a. THE CONTRACTOR SHALL VERIFY, BY FIELD CHECK, ALL SIZES, DIMENSIONS, ELEVATIONS, LOCATIONS, ETC OF ELEMENTS OF THE EXISTING CONSTRUCTION WHICH ARE RELATIVE TO THE NEW CONSTRUCTION.
- b. ALL DIMENSIONS INVOLVING NEW WORK TYING INTO OR GOVERNED BY EXISTING CONSTRUCTION SHALL BE FIELD CHECKED BY THE CONTRACTOR AND FURNISHED TO THE SUBCONTRACTOR PRIOR TO FABRICATION OF ANY WORK. THE VERIFIED DIMENSIONS SHALL APPEAR AND BE NOTED AS SUCH ON THE FIRST SHOP DRAWING SUBMITTED.
- c. THE ENGINEER HAS MADE ASSUMPTIONS CONCERNING THE SOUNDNESS OF THE EXISTING BUILDING AND THESE ASSUMPTIONS ARE THAT THIS BUILDING WAS DESIGNED AND CONSTRUCTED IN CONFORMITY WITH GOOD DESIGN AND CONSTRUCTION PRACTICES.
- d. THE CONTRACTOR SHALL TAKE EXTRAORDINARY PRECAUTIONS CONCERNING PRESERVATION OF THE BUILDING DURING DEMOLITION AND NEW CONSTRUCTION WORK. FURTHER, HE SHALL AGREE TO ASSUME ALL RESPONSIBILITY FOR THE PRESERVATION OF THIS PROPERTY. THE CONTRACTOR SHALL NOTIFY THE ARCHITECT/ENGINEER IMMEDIATELY OF ANY DISCREPANCIES BETWEEN CONSTRUCTION DOCUMENTS AND ACTUAL FIELD CONDITIONS.
- e. ALL HOLES THROUGH EXISTING CONCRETE OR MASONRY CONSTRUCTION SHALL BE CORE DRILLED OR SAW CUT. NEW OPENINGS MUST BE MADE WITH ENGINEER'S APPROVAL.
- f. CUTTING OF EXISTING STRUCTURAL STEEL IS PROHIBITED WITHOUT APPROVAL FROM THE ENGINEER.

12. SHOP DRAWINGS:

- a. SHOP DRAWINGS, UNLESS OTHERWISE NOTED, SHALL BE SUBMITTED FOR REVIEW PRIOR TO FABRICATION.
- b. SHOP DRAWINGS SHALL BE PREPARED UNDER THE SUPERVISION OF A REGISTERED PROFESSIONAL ENGINEER, AND INCLUDE COMPLETE DETAILS SCHEDULES, PROCEDURES AND DIAGRAMS FOR FABRICATION AND ASSEMBLY OF STRUCTURAL MEMBERS.
- c. FABRICATORS SHALL DRAW THEIR OWN ERECTION PLANS. COPYING STRUCTURAL PLANS AND USING THEM AS ERECTION DRAWINGS IS NOT ACCEPTABLE.
- d. PRIOR TO SUBMITTAL, THE CONTRACTOR SHALL REVIEW THE SHOP DRAWINGS AND MAKE ANY CORRECTIONS REQUIRED. THE CONTRACTOR SHALL STAMP AND SIGN THE DRAWINGS AS EVIDENCE THAT HE HAS REVIEWED THEM.
- e. SHOP DRAWINGS SHALL BE FURNISHED FOR ALL STRUCTURAL COMPONENTS.
- f. TURN AROUND TIME FOR SHOP DRAWINGS SHALL BE TWO WEEKS FROM DATE RECEIVED IN THE ENGINEER'S OFFICE.

13. IBC SPECIAL INSPECTION REQUIREMENTS

SPECIAL INSPECTIONS SHALL BE PROVIDED IN ACCORDANCE WITH IBC SECTION 1705, AS OUTLINED BELOW. THE SPECIAL INSPECTOR SHALL BE EMPLOYED BY THE OWNER, SHALL BE THOROUGHLY KNOWLEDGEABLE OF IBC SPECIAL INSPECTION REQUIREMENTS AND SHALL DEMONSTRATE COMPETENCE TO THE SATISFACTION OF THE BUILDING OFFICIAL (IBC 1704.2.1). THE CONTRACTOR SHALL CONTACT THE SPECIAL INSPECTOR DURING APPROPRIATE PHASES OF CONSTRUCTION SO THAT INSPECTIONS CAN BE MADE IN A TIMELY MANNER. THE SPECIAL INSPECTOR SHALL SUBMIT WRITTEN INSPECTION REPORTS TO THE ENGINEER OF RECORD'S OFFICE, WITHIN 3 WORKING DAYS OF EACH INSPECTION. ANY PROBLEMS SHOULD BE BROUGHT TO THE IMMEDIATE ATTENTION OF THE CONTRACTOR. THE FOLLOWING ITEMS WILL REQUIRE SPECIAL INSPECTION:

- a. CONCRETE
 - REINFORCEMENT: REINFORCING STEEL SHALL BE INSPECTED ON A PERIODIC BASIS. WELDING OF REINFORCEMENT SHALL BE CONTINUOUSLY INSPECTED. ONLY ASTM A706 REINFORCEMENT MAY BE WELDED.
 - SAMPLING AND TESTING: CONTINUOUS INSPECTIONS SHALL BE PROVIDED DURING SLUMP TESTS, AIR CONTENT TESTS AND WHEN DETERMINING THE TEMPERATURE OF FRESH CONCRETE AT THE TIME OF MAKING SPECIMENS FOR STRENGTH TESTS.
 - CONCRETE PLACEMENT: PERIODIC INSPECTION REQUIRED.
 - COLD AND HOT WEATHER CONCRETING. PERIODIC INSPECTION OF COMPLIANCE IS REQUIRED.

Larson Engineering, Inc.
3524 Labore Road
White Bear Lake, MN 55110-5126
651.481.9120 Fax: 651.481.9201
www.larsonengr.com

SUBJECT 6670 VERNON AVE STAIR
EDINA, MN

SHEET NO. IV OF _____
PROJECT NO. 11-19-081C
BY J. Lee DATE 6/25/19
CHECKED BY: _____



- ERECTION OF PRECAST CONCRETE MEMBERS: PERIODIC INSPECTION REQUIRED.
- b. PILE FOUNDATIONS
 - A SPECIAL INSPECTOR SHALL BE PRESENT WHEN PILE FOUNDATIONS ARE BEING INSTALLED AND DURING TESTS. THE SPECIAL INSPECTOR SHALL MAKE AND SUBMIT TO THE BUILDING OFFICIAL RECORDS OF THE INSTALLATION OF EACH PILE AND RESULTS OF THE LOAD TESTS. RECORDS INCLUDE THE CUTOFF AND TIP ELEVATION OF EACH PILE.
- 14. IBC SPECIAL INSPECTION TESTING REQUIREMENTS
 - a. CONCRETE
 - SAMPLE FOR STRENGTH TESTS OF EACH CLASS OF CONCRETE PLACED EACH DAY SHALL BE TAKEN NOT LESS THAN ONCE A DAY, NOR LESS THAN ONCE FOR EACH 150 CUBIC YARDS OF CONCRETE, NOR LESS THAN ONCE FOR EACH 5,000 SQUARE FEET OF SURFACE AREA FOR SLABS OR WALLS. A MINIMUM OF FIVE STRENGTH TESTS SHOULD BE MADE FOR A GIVEN PROJECT.



NOTE:
 -LOADS SHOWN ON PLAN
 ARE UNFACTORED
 SERVICE LEVEL LOADS
 -SEE SHEET S1 OF MATTSO
 MACDONALD YOUNG (MMY #19083)
 DWGS FOR FDN DIMENSIONS.

SCOPE
 -LARSON ENGINEERING'S SCOPE
 OF WORK INCLUDES DESIGN OF
 THE GRADE BM AND LOAD
 DETERMINATION FOR HELICAL
 PILES ONLY. ALL OTHER ELEMENTS
 OF PROJECT ARE THE RESPONSIBILITY
 OF OTHERS.

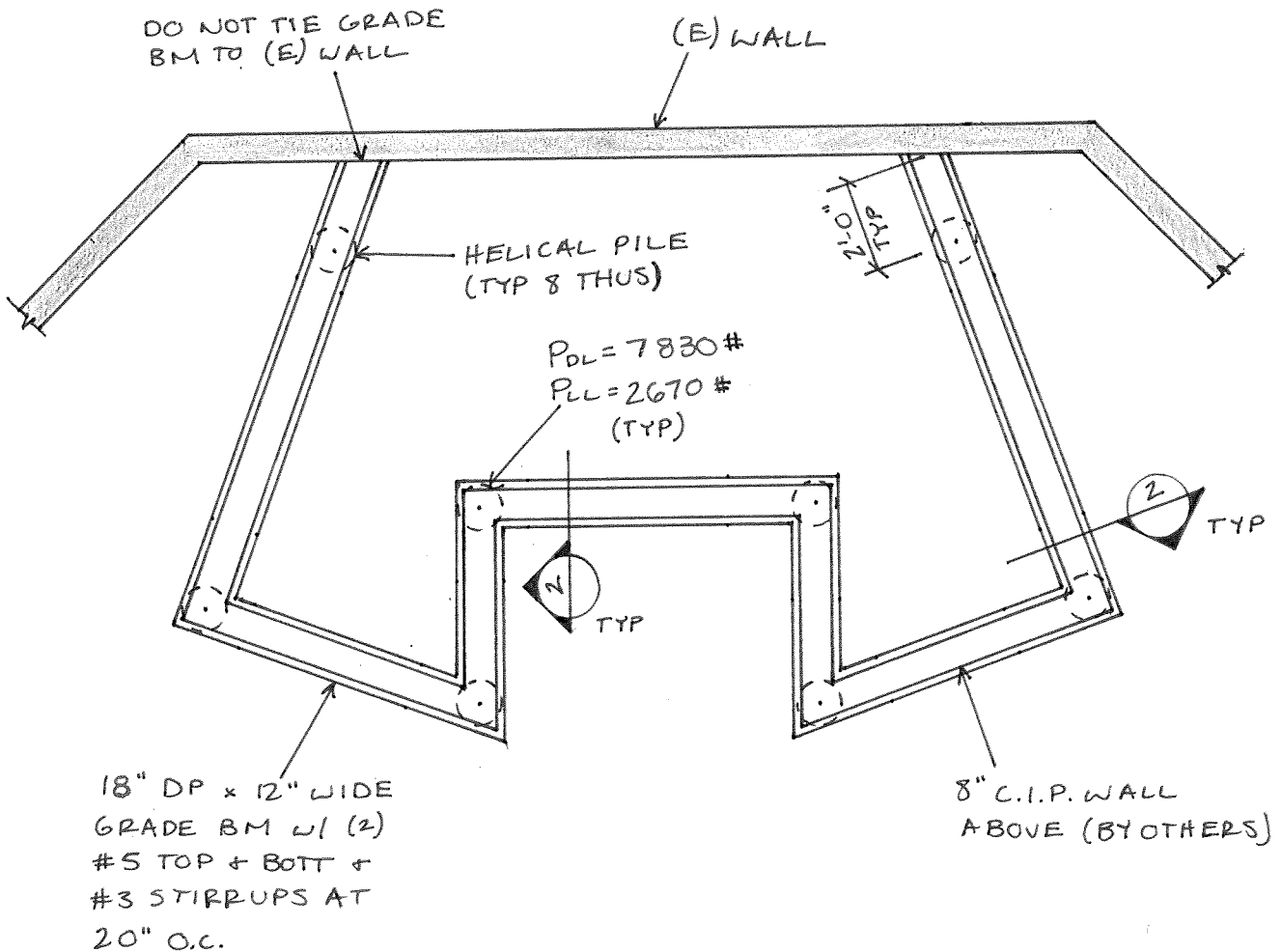

1 FOUNDATION PLAN
 NTS

Larson Engineering, Inc.
3524 Labore Road
White Bear Lake, MN 55110-5126
651.481.9120 Fax: 651.481.9201
www.larsonengr.com

SUBJECT 6670 VERNON AVE STAIR
EDINA, MN

SHEET NO. 2 OF _____
PROJECT NO. 11-19-0816
BY J. Lee DATE 6/25/19
CHECKED BY: _____

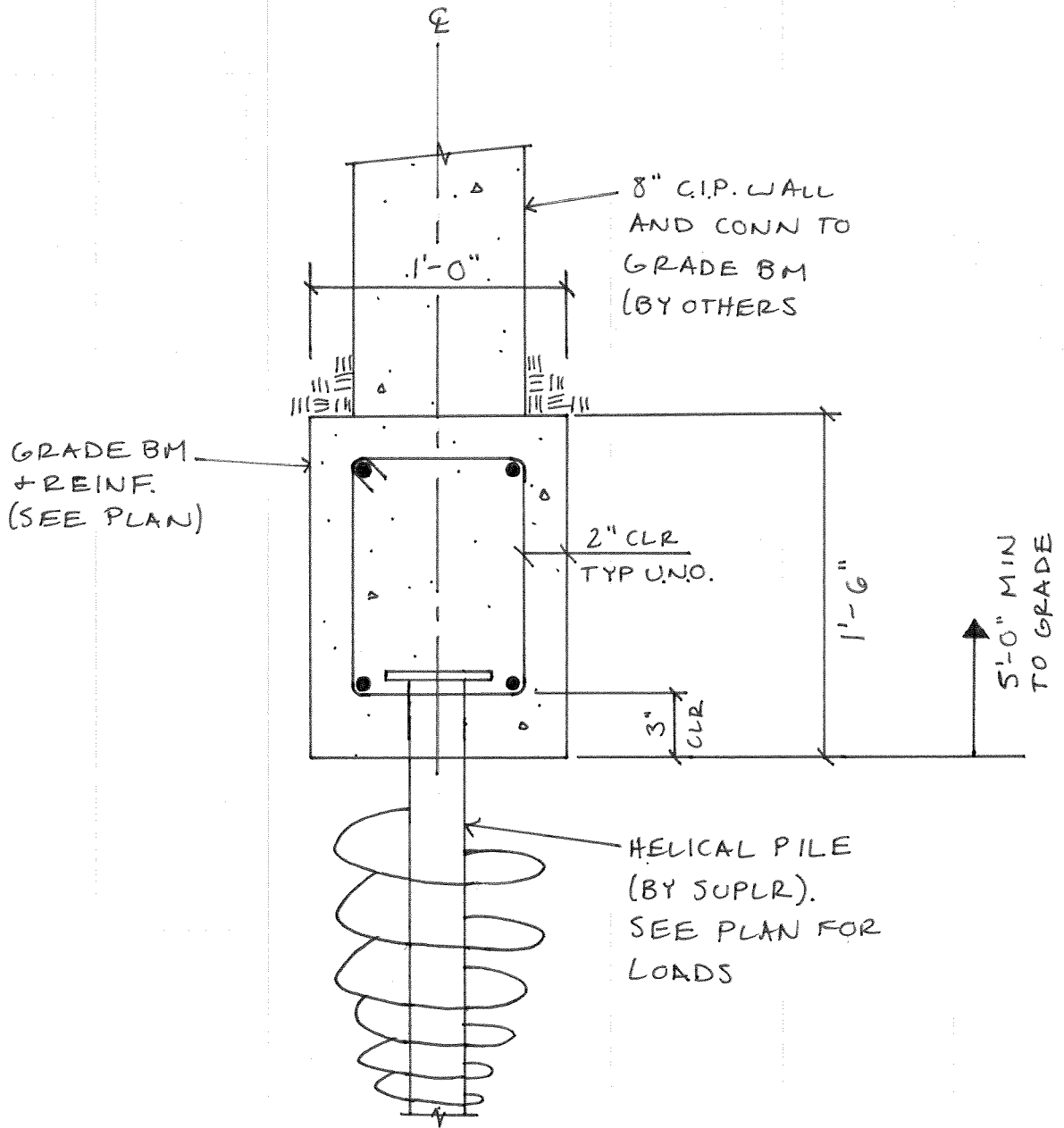

2 SECTION
NTS