



Date	Customer	Job Name	P.O. / S.O.

Variable Frequency Drive (VFD)
Z1000 Mechanical Specification Submittal
(For NEMA 1 Rated Drives)

GENERAL

The Z1000 is a high performance PWM (pulse-width-modulated) AC drive. Three-phase input line power is converted to a sine-coded, variable frequency output, which provides optimum speed control of any conventional squirrel cage induction motor and permanent magnet motor. The use of IGBTs (Insulated Gate Bipolar Transistors), with a carrier frequency range of 1 kHz to 12.5 kHz, permits quiet motor operation.

This drive has one control logic board for all horsepower ratings. Printed circuit boards employ surface mount technology, providing both high reliability, and small physical size of the printed circuit assemblies. The dual 32 bit microprocessors deliver the computing power necessary for complete three phase motor control in building automation systems.

Operating Principle: Input three phase AC line voltage is first rectified to a fixed DC voltage. Using pulse width modulation (PWM) inverter technology, the DC voltage is processed, to produce an output waveform in a series of variable-width pulses. Unique firmware algorithms optimize motor magnetization through control of voltage, current and frequency applied to generate a nearly sinusoidal output waveform.

STANDARDS

UL 508C (Power Conversion)

CSA 22.2 No. 14-95 (Industrial Control Equipment)

UL 1995 (Plenum)

CE mark 2006/95/EC LVD

CE mark 2004/108/EC

IEC 61800-5-1 (LVD)

EN 61800-3

IEC 529

IEEE C62.41

BTL Listed

UL, cUL listed; CE marked

ENVIRONMENTAL & SERVICE CONDITIONS

Ambient service temperature:

NEMA 1 (IP20): -10°C to 40°C (14°F to 104°F)

SG.Z1000.10

Ambient storage temperature: -20°C to 70°C (-4°F to 158°F)

Humidity: 0 % to 95 %, non-condensing

Altitude: to 1000 meters (3300 feet), higher by derating

Service factor: 1.0

Vibration: 9.81m/s² (1 G) maximum at 10 to 20 Hz, 2.0 m/s² (0.2 G) at 20 Hz to 55 Hz.

Plenum mounting capable (IP20)

RoHS Compliant

QUALITY ASSURANCE

In circuit testing of all printed circuit boards is conducted, to ensure proper manufacturing.

Final printed circuit board assemblies are functionally tested, via computerized test equipment.

All fully assembled controls are computer tested with induction motor loads to assure unit specifications are met.

The average MTBF (Mean Time Between Failure) is 28 years

CONSTRUCTION

Input Section - VFD power input stage converts three phase AC line power into a fixed DC voltage, via a solid state full wave diode rectifier, with MOV (Metal Oxide Varistor) surge protection. An internal 5% DC bus reactor reduces harmonics for cleaner power.

Intermediate Section - DC bus maintains a fixed DC voltage, with filtering and short circuit protection, as a DC supply to the VFD output section. It is interfaced with the VFD diagnostic logic circuit, to continuously monitor and protect the power components.

Output Section - Insulated Gate Bipolar Transistors (IGBTs) convert DC bus voltage to a variable frequency and voltage, utilizing a PWM sine-coded output to the motor. IGBT output allows motor noise, at 60 Hz, to measure less than 2 dB (@ 1 meter) above that resulting from across the line operation.

Power and control electronics housings:

NEMA 1 (IP20) wall-mounted enclosure:

208 V, 3 thru 100 HP; 480 V, 3 thru 250 HP

CONSTRUCTION (continued)

Microprocessor based control circuit

Non-Volatile memory (NV RAM); all programming memory is saved when the VFD is disconnected from power.

Current transformers detect the output current for motor control and protective functions

Digital operator keypad and display, with copy function, provides local control and readout capability:

Hand/Off/Auto commands

Speed Reference command

Reset command

Easy to remove heat sink cooling fan with programmable on/off control

USB Type B port for quick and easy PC Connection

PRODUCT FEATURES

Displacement power factor of .98 throughout the motor speed range

Input phase insensitive; sequencing of the three phase input is unnecessary

Internal EMI/RFI filter complies with IEC 61800-3 restricted distribution for first environment

Built-In real time clock for time and date stamping events along with timer functions for starting, stopping and speed changes without the need for external controls

Volt meter, ammeter, kilowatt meter elapsed run time meter and heat sink temperature monitoring functions

Two internal (PI) Controls

1. Drive internal PI closed loop control with selectable engineering units
2. Independent PI control for use with external device

Differential PI feedback feature

Sleep function in both closed loop and open loop control

Feedback signal low pass filter

Feedback signal loss detection and selectable response strategy

Feedback signal inverse and square root capability

24 Vdc, 150ma transmitter power supply

Input and output terminal status indication

Diagnostic fault indication

VFD efficiency: 96% at half-speed; 98% at full-speed

“S-curve” soft start / soft stop capability

Run/Fault output contacts

Serial communication loss detection and selectable response strategy

“Up/Down” floating point control capability

Controlled speed range of 40:1

Critical frequency rejection capability: 3 selectable, adjustable bandwidths

100% starting torque capability, available from 3 Hz to 60 Hz

Remote speed reference (speed command) signal:

0 to 10 VDC (20 k Ω)

4 to 20 mA DC (250 Ω)

Adjustable carrier frequency, from 1 kHz to 12.5 kHz

Dynamic noise control for quiet motor operation

Programmable security code

7 programmable multi-function input terminals (24Vdc) providing 60+ programmable features, including:

Customer Safeties

BAS / Damper Interlock

Emergency Override

Preset Speed

PI control enable / disable

3 programmable multi-function output relays (Form A rated 2 amps @ 250Vac & 30Vdc), providing 50+ functions, including:

Damper control

Hand / Auto Status

Contact Control for External Bypass

Overtorque/undertorque detection

Serial communication status

No load detection (broken belt alert)

One fixed “Fault” form C output relay (Rated 2 amps @ 250Vac & 30Vdc)

7 preset speeds

Built-in BACnet protocol along with Modbus/Memobus. Protocol are accessible via RS-422/485 communication, which is standard

Stationary motor auto-tuning

“Kinetic Energy Braking” (KEB) function stops the motor in up to half the time it would take without this function.

LCD keypad: Hand/Off/Auto functions with a built-in copy feature,

Motor preheat function

Flash upgradeable firmware

Customizable monitor display

Heat sink over temperature speed fold-back feature

“Bumpless” transfer between Hand and Auto modes

Emergency override can be used as “smoke purge” function

Fan failure detection and selectable drive action

OPERATION

Output frequency and speed display can be programmed for other speed-related and control indications, including: RPM, CFM, GPM, PSI, in WC, % of maximum RPM or custom

Power loss ride-thru (2 seconds capable)

Time delay on start, peak avoidance

VFD accepts either a direct acting or a reverse acting speed command signal

Bi-directional "Speed Search" capability, in order to start into a rotating load. Two types: current detection and residual voltage detection

DC injection braking, to prevent fan "wind milling"

Remote Run/Stop command input

Two programmable 0 to 10 VDC or 4-20ma analog outputs, proportional to drive monitor functions including: output frequency, output current, output power, PI feedback, output voltage and more.....

5-Line 16 Character LCD display provides readout functions that include: output frequency, output voltage, output current, output power, DC bus voltage, interface terminal status, PI feedback and fault status.

Programmable HVAC specific application macros

Over 100 programmable functions, resettable to factory HVAC presets

User parameter initialization, re-establish project specific parameters

Ramp-to-stop or coast-to-stop selection

Auto restart capability: 0 to 10 attempts with adjustable delay time between attempts

One custom selectable Volts/Hertz pattern and multiple preset Volts/Hertz patterns

Auto speed reference input signal, adjustable for bias and gain

While the VFD is running, operational changes in control and display functions are possible, including:

- Acceleration time (0 to 6000 seconds)

- Deceleration time (0 to 6000 seconds)

- Frequency reference command

- Hand/Off/Auto commands

- Monitor display

- Removable digital operator

Automatic energy saving, reduced voltage operation

PROTECTION

Output current overload rating of 110 % of drive's continuous current rating for 60 seconds

Output short circuit protection

Current limited stall prevention (overload trip prevention) during acceleration, deceleration, and run conditions

Optically isolated operator controls

Fault display and last 10 faults storage

"Hunting" prevention logic

Electronic ground fault protection

Electronic thermal motor overload protection (UL approved)

DC bus charge indication

Heat sink over temperature protection

Cooling fan operating hours recorded

Input/Output phase loss protection

Reverse prohibit selectability

Short circuit withstand rating of 100K amps RMS

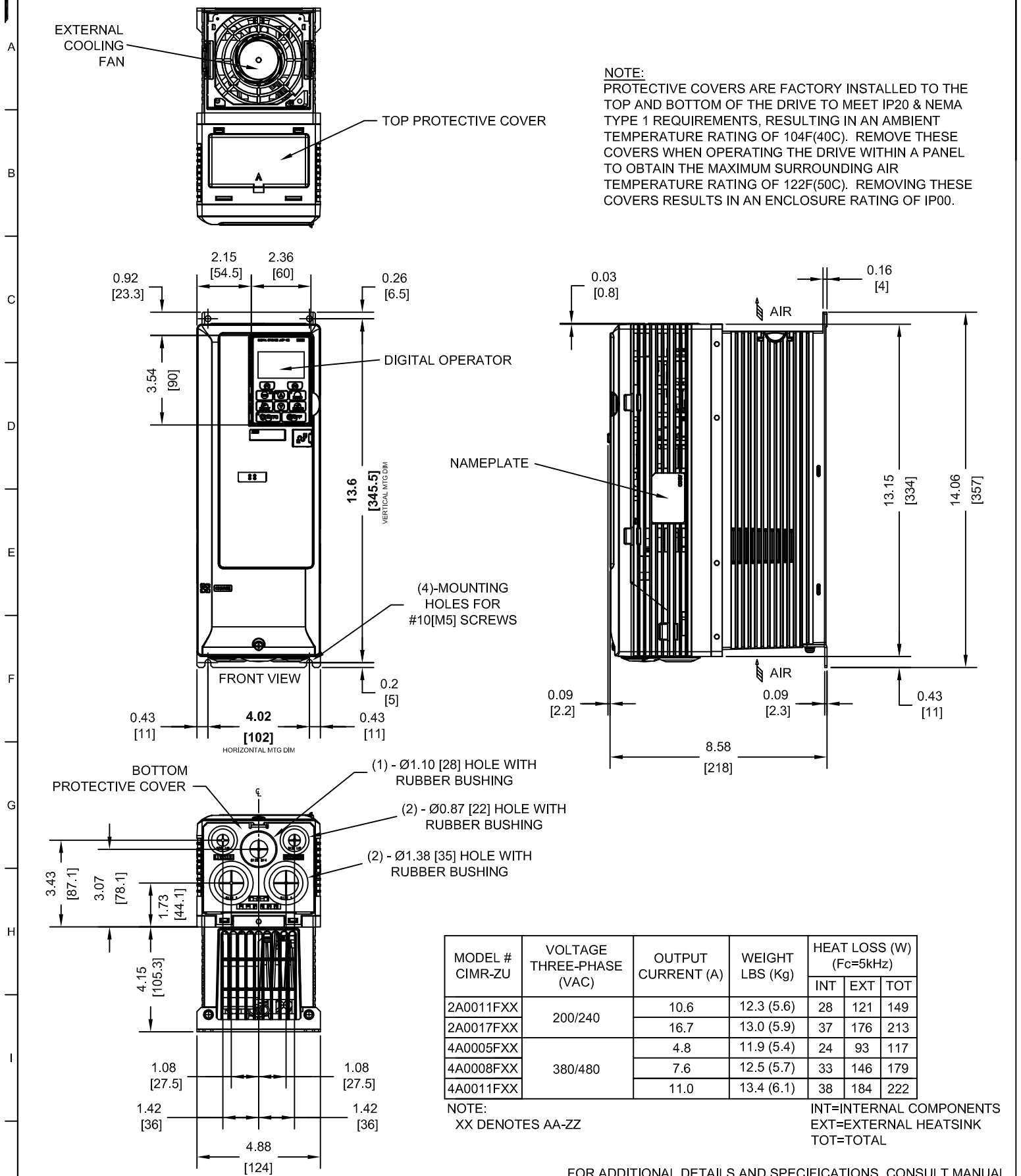

MODEL # CIMR-ZU	VOLTAGE THREE-PHASE (VAC)	OUTPUT CURRENT (A)	WEIGHT LBS (Kg)	HEAT LOSS (W) (Fc=5kHz)		
				INT	EXT	TOT
2A0011FXX	200/240	10.6	12.3 (5.6)	28	121	149
2A0017FXX		16.7	13.0 (5.9)	37	176	213
4A0005FXX	380/480	4.8	11.9 (5.4)	24	93	117
4A0008FXX		7.6	12.5 (5.7)	33	146	179
4A0011FXX		11.0	13.4 (6.1)	38	184	222

NOTE:
 XX DENOTES AA-ZZ
 INT=INTERNAL COMPONENTS
 EXT=EXTERNAL HEATSINK
 TOT=TOTAL

FOR ADDITIONAL DETAILS AND SPECIFICATIONS, CONSULT MANUAL

TOLERANCES / REFERENCES: YASKAWA THIS DOCUMENT AND INFORMATION CONTAINED IN IT ARE CONFIDENTIAL, AND CANNOT BE COPIED OR DISCLOSED IN WHOLE OR IN PART WITHOUT THE EXPRESS WRITTEN CONSENT OF YASKAWA AMERICA, INC.	DRAWN: J. MATTAS DATE: 8-23-11	TITLE: Z1000 DIMENSION DRAWING FRAME SIZE 1 NEMA TYPE 1 ENCLOSURE 2A0011 - 0017, 4A0005 - 0011
	CHECKED: J. PIOTROWSKI DATE: 10-21-11	REVISION: R00
	TECH: J. BORJA DATE: 9-22-11	PAGE: 1 of 3
	APPROVED: J. CAIRO DATE: 10-17-11	DRAWING #: DD.Z1K.FR1.N1
UNITS: IN [mm]	SCALE: 1:5	ORIGINAL DESIGN: -

TERMINAL AND WIRING DETAILS (SCALE 1:3)

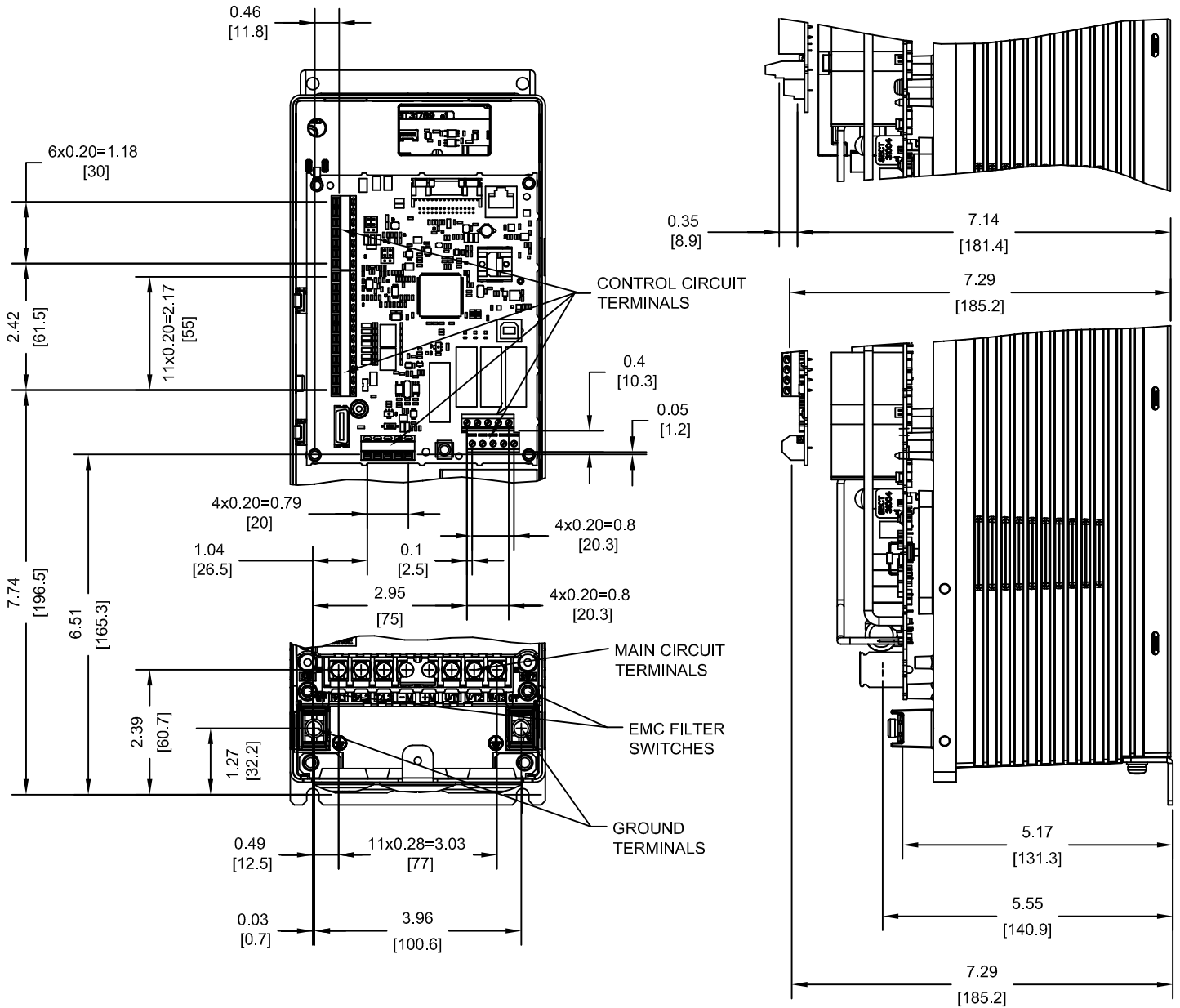

TERMINAL AND WIRE SPECIFICATIONS FOR MAIN CIRCUIT AND GROUND

MODEL # CIMR-ZU	TERMINAL SYMBOL	TERMINAL SCREW	CLAMPING TORQUE lb.in.(N.m)	WIRE RANGE AWG(mm ²)
2A0011 2A0017 4A0005	R/L1, S/L2, T/L3, U/T1, V/T2, W/T3, -M, +M	M4	14 TO 16 (1.6 TO 1.8)	24-8 (0.25-10)
4A0008 4A0011	⊕	M5	24 TO 27 (2.7 TO 3.0)	

NOTE: REFER TO APPLICABLE CODES FOR PROPER WIRE TYPE AND SIZE

FOR ADDITIONAL DETAILS AND SPECIFICATIONS, CONSULT MANUAL

TOLERANCES / REFERENCES:	<p>THIS DOCUMENT AND INFORMATION CONTAINED IN IT ARE CONFIDENTIAL, AND CANNOT BE COPIED OR DISCLOSED IN WHOLE OR IN PART WITHOUT THE EXPRESS WRITTEN CONSENT OF YASKAWA AMERICA, INC.</p>	DRAWN: J. MATTAS DATE: 8-23-11	TITLE: Z1000 DIMENSION DRAWING			
		CHECKED: J. PIOTROWSKI DATE: 10-21-11	FRAME SIZE 1 NEMA TYPE 1 ENCLOSURE 2A0011 - 0017, 4A0005 - 0011			
		TECH: J. BORJA DATE: 9-22-11	SIZE A	REVISION R00	PAGE 2 of 3	
		APPROVED: J. CAIRO DATE: 10-17-11	DRAWING #: DD.Z1K.FR1.N1			
UNITS: IN [mm]	SCALE: BY VIEW	ORIGINAL DESIGN: -	DATE: -			

MINIMUM INSTALLATION CLEARANCES (SCALE 1:8)

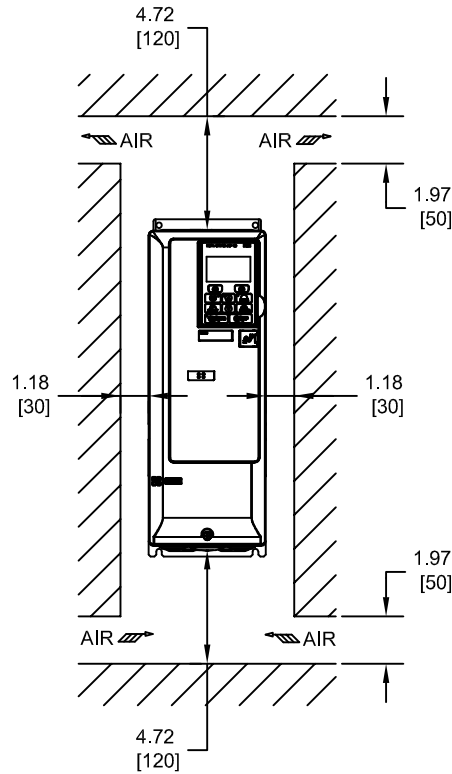

NOTE:
FOR SIDE-BY-SIDE MOUNTING
CONSULT MANUAL

PANEL CUTOUT FOR EXTERNAL HEATSINK
MOUNTING CONFIGURATION (SCALE 1:6)

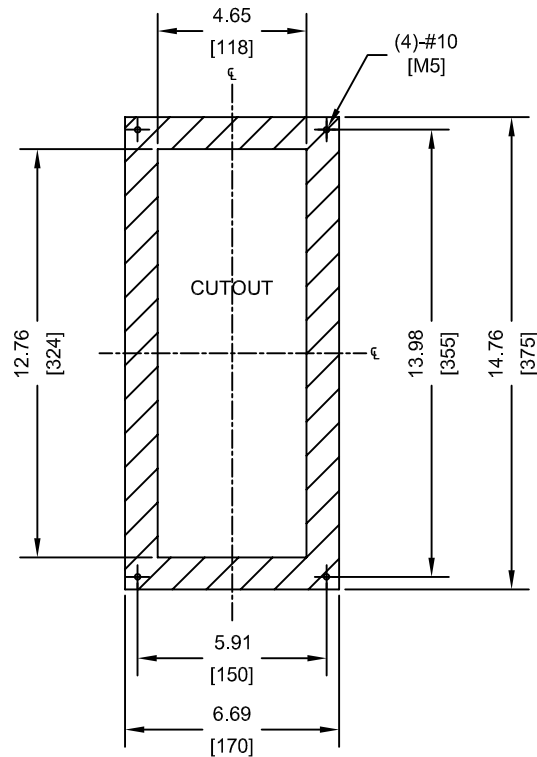

NOTES:

1. EXTERNAL HEATSINK CONFIGURATION REQUIRES MOUNTING KIT
2. CUTOUT TOLERANCES: +/- 0.02IN (0.5MM)
3. EXPOSED HEATSINK DEPTH D=4.15" MINUS PANEL THICKNESS

FOR ADDITIONAL DETAILS AND SPECIFICATIONS, CONSULT MANUAL

TOLERANCES / REFERENCES:			DRAWN: J. MATTAS 8-23-11	TITLE: Z1000 DIMENSION DRAWING	
			CHECKED: J. PIOTROWSKI 10-21-11	FRAME SIZE 1 NEMA TYPE 1 ENCLOSURE 2A0011 - 0017, 4A0005 - 0011	
		THIS DOCUMENT AND INFORMATION CONTAINED IN IT ARE CONFIDENTIAL, AND CANNOT BE COPIED OR DISCLOSED IN WHOLE OR IN PART WITHOUT THE EXPRESS WRITTEN CONSENT OF YASKAWA AMERICA, INC.	TECH: J. BORJA 9-22-11	DATE: 9-22-11	
UNITS: IN [mm]	SCALE: BY VIEW		APPROVED: J. CAIRO 10-17-11	DATE: 10-17-11	SIZE: A
			ORIGINAL DESIGN: -	DATE: -	PAGE: 3 of 3
			DRAWING #: DD.Z1K.FR1.N1		